

SECTION 9: BODY HARDWARE

- 9.1 Mudguards
- 9.2 Bonnets
- 9.3 Window Glass
- 9.4 Mirrors
- 9.5 Seat Belts and Mounts
- 9.6 Seating
- 9.7 Fuel Tank Systems
- 9.8 Door Latches
- 9.9 Automatic Transmission Selectors
- 9.10 Number-Plates
- 9.11 Chop-Tops
- 9.12 Vehicle Identification

9.1 MUDGUARDS

- 9.1.1 Mudguards must be fitted on the front and rear wheels except for wheels/tyres that are enclosed by the body.
- 9.1.2 A mudguard must effectively cover the width of the tread surface and at least one third of the circumference of the tyre, and must extend 15° forward of the vertical axle centreline and 15° below the horizontal axle centreline at the rear of the axle.
- 9.1.3 Rear inner guards must not be “tubbed” to accommodate wheel rims wider than 10”.
- 9.1.4 The forward edge of the front mudguards must have a minimum radius of 2.5mm, and have no sharp edges or protrusions likely to injure any person.

9.2 BONNETS

- 9.2.1 Where a bonnet is fitted, it must provide protection against accidental contact with moving pulleys and belts, cooling and alternator fan as required by Clauses 2.2.2 and 2.2.3.
Note: Street Rods should be presented for registration in the configuration they are intended to be used – if it is intended to be driven with the bonnet fitted, it should be fitted; if it is intended to be driven with the bonnet removed, it should be removed.
- 9.2.2 All bonnets must be securely mounted and fitted with a latching device that will prevent opening while moving. Bonnets that open from the front should have a secondary latching device.
- 9.2.3 Air cleaners, scoops etc may protrude through the bonnet or past the bonnet line where no bonnet is fitted, provided that their edges are radiused to reduce the likelihood of injury.
- 9.2.4 Protrusions through the bonnet must not obstruct the driver’s line of view – refer to Clause 10.2.

9.3 WINDOWS GLASS

- 9.3.1 All glass used in windscreens, windows and transparent wind deflectors must be safety glass suitable for automotive use. Information and guidance on this is provided in Appendix G of Section LZ Appendices of VSB 14. All non-glass materials used for these items must be shatterproof.
- 9.3.2 Windscreens must have a minimum light transmittance of 70%; other windows must have a minimum light transmittance of 35% or the value specified by the law of the jurisdiction.

9.4 MIRRORS

- 9.4.1 All Street Rods must be fitted with at least one rear vision mirror on the right side, and at least one rear vision mirror on the left side or inside.
- 9.4.2 Internal mirrors should be mounted centrally and have a flat profile. The profile of external mirrors may be flat or curved (convex) with a minimum radius of 1.2 metres, or a combination of flat and curved.
- 9.4.3 Left-hand drive Street Rods must be fitted with a rear vision mirror on its left side.

9.5 SEATBELTS AND MOUNTS

- 9.5.1 Seatbelts must be provided for all seating positions.
 - 9.5.2 Except where otherwise permitted, inertia reel lap-and-sash belts must be provided for all outboard seating positions and lap belts for centre positions. Where the construction of the Street Rod cannot provide adequate mounting points for lap/sash belts, lap belts may be used.
 - 9.5.3 All seatbelts fitted must be unused and in pristine condition, and comply with AS 2596 *Seat belt assemblies for motor vehicles*.
 - 9.5.4 When full harness seatbelts are fitted, they must comply with ADR 4/05 *Seatbelts* or Confederation of Australian Motor Sport Inc specifications. Full harness seatbelts must not be installed where there are rear passenger seats unless approval is obtained from the registering authority.
 - 9.5.5 Seatbelt anchorage points must be installed in accordance with ADR 5/05 *Anchorage for seat belts*.
 - 9.5.6 Seatbelts must be installed using the hardware (bolts, nuts anchor plates, washers, spacers etc) provided by the seat belt manufacturer for that purpose. Typically they must be connected to the seat belt anchorage with 7/16" or 11mm seat belt bolts or, where required, harness connectors that comply with ADR4/00 and designed only for this purpose. A locking device or a nyloc nut must retain each bolt that attaches to a non-captive nut.
 - 9.5.7 Seatbelts must be mounted in a fashion that avoids the likelihood of chafing or damage to the webbing. Where appropriate, seat belt anchor plates must be able to pivot.
 - 9.5.8 Seatbelts are designed to bear upon the bony structure of the body. Lap belts must be mounted so that they can be worn low across the front of the pelvis. Lap/sash belts must be mounted so that lap portion of the belt supports the pelvis while the upper portion of the belt supports the chest and shoulders, without chafing the wearer's neck.
 - 9.5.9 Figures 9(a) and 9(b) (Drawings TAC-11 and TAC-12) illustrate the location and correct mounting of seat belt anchorages.
 - 9.5.10 Child restraints anchorages must be installed in replica Street Rods.
- Note: A child restraint anchorage is necessary to properly secure a child restraint in a Street Rod. Australian Road Rules, as incorporated in the laws of every jurisdiction, prohibit a child to travel in a vehicle unless restrained in a suitable child restraint.
- 9.5.11 Seatbelts and their anchorages, and child restraints and their anchorages should be installed in accordance with Section LK Seating and Occupant Protection of VSB 14. Seat belts, child restraints and their respective anchorages so installed are deemed to comply with the abovementioned ADR requirements.

9.6 SEATING

- 9.6.1 Seats must be securely fitted and must not release under extreme deceleration.
- 9.6.2 Seat width determines the maximum number of seating positions. If unsure, an Examiner should be contacted for verification. The minimum seat width should be 410mm per occupant.
- 9.6.3 Sliding seat mounts must have a minimum of two bolts per side, of a minimum 8mm or 5/16" diameter.

- 9.6.4 Fixed seats must have a minimum of two bolts per side, of a minimum 8mm or 5/16" diameter.
- 9.6.5 Folding or hinged seats that tilt forward to gain access to rear seats or to luggage areas must be positively locked in the upright position.
- 9.6.6 If dickey-seats are fitted, there must be a positive means of locking the seat lid in both the open and closed positions.
- 9.6.7 Seats and their anchorages should be installed in accordance with Section LK Seating and Occupant Protection of VSB 14.

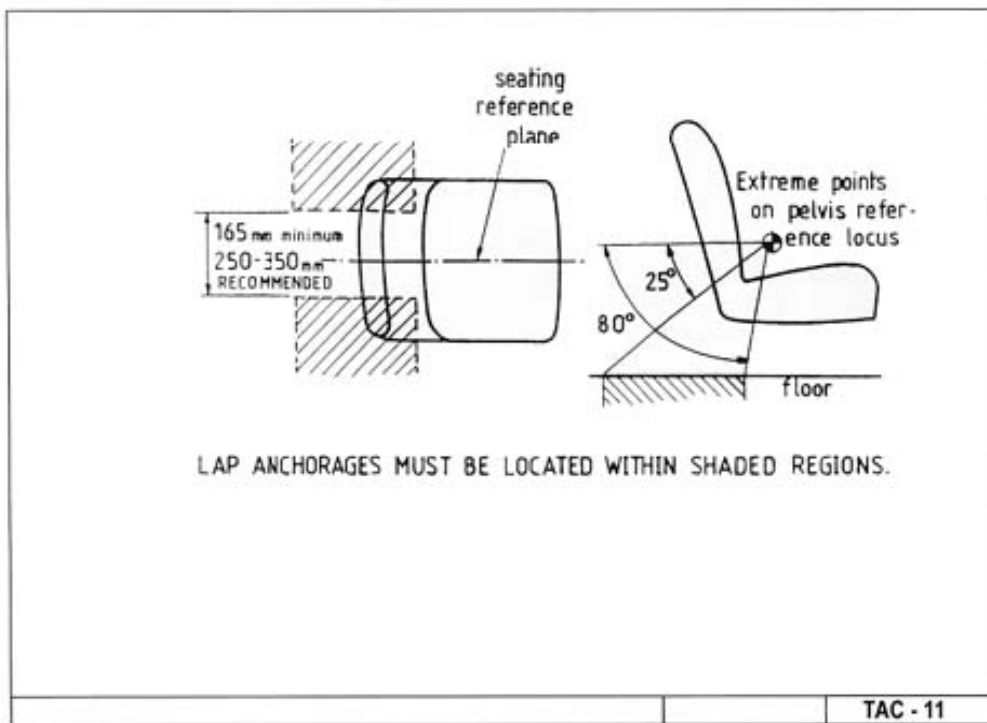

Figure 9(a) Location of seat belt anchorage (Drawing TAC-11)

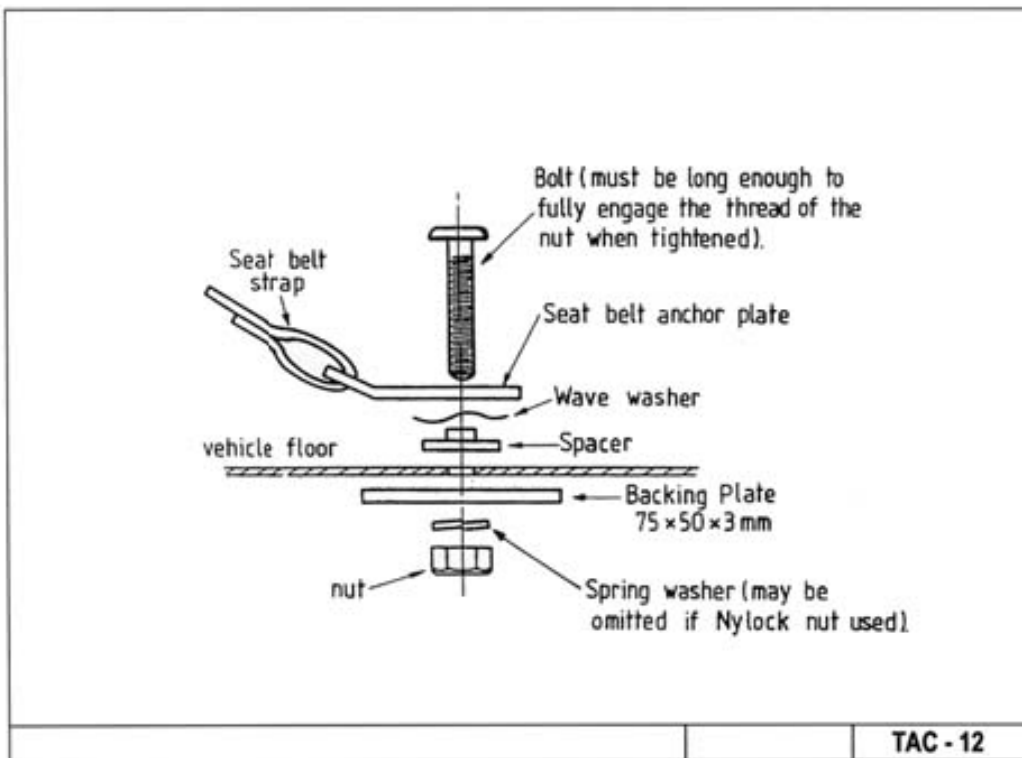

Figure 9(b) Detail of seat belt anchorage (Drawing TAC-12)

9.7 FUEL TANK SYSTEMS

9.7.1 Fuel tanks must be mounted in a position that prevents spillage of fuel or entry of fuel vapours into the passenger compartment. Fuel tank system components must be located clear of electrical components and exhaust systems.

9.7.2 Fuel tanks must be fitted with a safety vent that discharges outside the Street Rod away from any ignition source, or must have a closed evaporative emission control system such as a carbon or a charcoal canister.

9.7.3 Fuel tanks must be manufactured from corrosion resisting material to a thickness appropriate for the capacity of the tank with baffles or other methods fitted to prevent unnecessary movement of fuel. Fuel-proof plastic may be used. Aluminium tanks must have a minimum radius of 6mm on any bends, and must have a stamp that identifies the manufacturer with the fuel tank must be installed in accordance with the manufacturer's specifications.

9.7.4 Fuel lines must be secured at intervals of no more than 300mm. Rigid fuel lines must have a flexible connection where the fuel line passes between the chassis and a moving component.

9.7.5 Unprotected fuel lines must not pass under chassis rails.

9.7.6 Fuel tanks mounted higher than the carburettor float bowl must be fitted with a shut-off solenoid that automatically prevents fuel siphoning when the ignition is off.

9.7.7 All electrical components, battery and wiring, must be kept clear of the fuel tank and lines to prevent accidental combustion of spilled fuel or its vapours.

9.7.8 Street Rods that are to be fuelled by Liquefied Petroleum Gas or Natural Gas should be built to comply with the relevant installation codes of Section LM Fuel System of VSB 14, or in accordance with the Australian Standard AS/NZS 1425 *LP Gas fuel systems for vehicle engines* or AS/NZS 2739 *Natural Gas (NG) fuel systems for vehicle engines* as applicable.

9.8 DOOR LATCHES

Door latches must be of the double-catch type. Burst-proof door latches should be used.

9.9 AUTOMATIC TRANSMISSION SELECTORS

9.9.1 Transmission selectors must be designed so that there can be no accidental engagement of drive or reverse gear.

9.9.2 All replica Street Rods fitted with an automatic transmission must have an indicator in the driver's compartment showing the transmission control positions.

9.10 NUMBER PLATES

9.10.1 Front and rear number plates must be securely attached to the Street Rod no higher than 1.3 metres above the ground, and must be clearly visible and not obstructed in any way.

9.10.2 The front number plate must be mounted parallel to the front axle and be in the centre or the right hand side of the Street Rod.

9.10.3 The rear number plate must be mounted parallel to the rear axle.

9.10.4 The identification characters on a number plate must be legible from a distance of 20 metres and within the area described by a 45° arc, at any point above or to either side of the surface of the number plate, as shown in Figure 9(c) below.

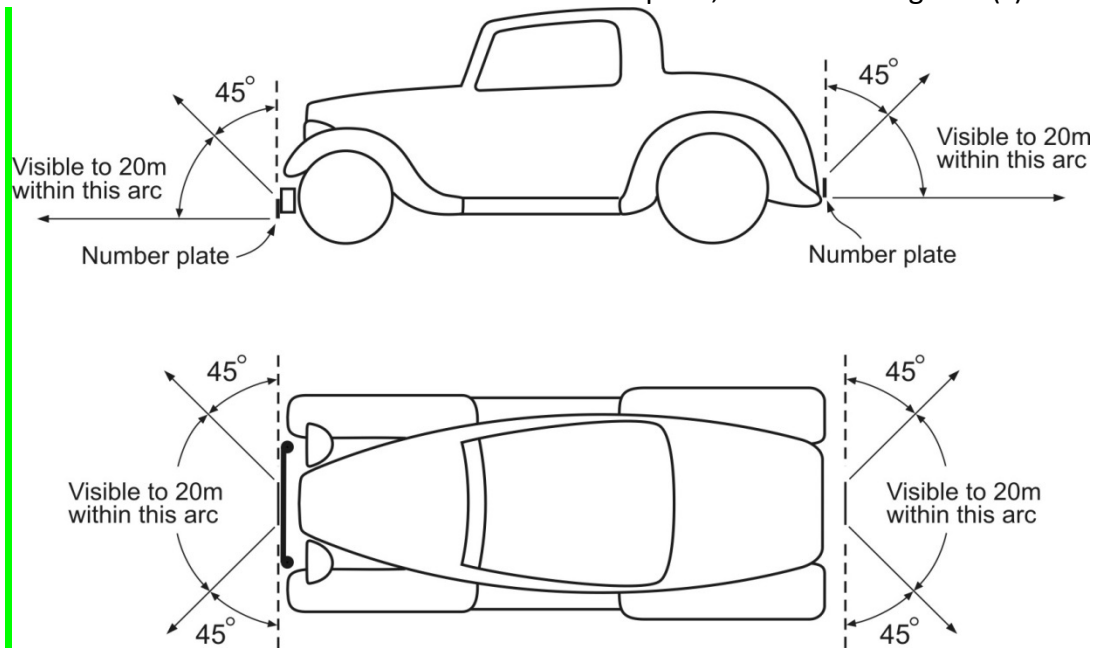

Figure 9(c) Position of number plates

9.11 CHOP-TOPS

9.11.1 For Street Rods converted or manufactured with a reduced roof line, to prevent injury to the occupants in the event of their head contacting the roof during normal driving conditions, the interior roof must either have a full headlining or energy absorbing material must be attached locally above the occupants' positions.

9.11.2 Driver forward vision must not be impaired and must meet the requirements specified in Section 10.2. Windscreen wiper(s) must comply with Section 8.4. The mirrors must comply with Section 9.4; if necessary, external rear view mirrors must be fitted to both sides of the Street Rod.

9.12 VEHICLE IDENTIFICATION

9.12.1 All Street Rods must have a unique identification number.

9.12.2 For modified vehicles or replicas built before 1 January 1989, the identification number may be a chassis or frame number; refer to Section 3.1.

9.12.3 For replica vehicles built after 1 January 1989, the identification number must be a vehicle identification number (VIN) issued by a registering authority.

9.12.4 The VIN must be attached to the vehicle so that that its characters are legible, durable and not easily altered. The VIN must be attached by one of the following ways:

- (a) The VIN is marked directly on an integral part of the vehicle, such as the frame or a part of the body that is not easily removable.
- (b) The VIN is marked on a separate plate that is permanently affixed to the vehicle in accordance with (a) above.
- (c) A combination of (a) and (b) above.