

**Confidential - Safety Recall Campaign**

To:	All Dealers
Attention:	All Dealer Principals/General Managers, Service Managers & Workshop Staff
Bulletin Number:	24 RC 002
From:	LDV Technical Support
Date:	31/10/2024
Pages:	3
Subject:	LDV2437 Deliver 9 Low Pressure Fuel Line Inspection

The purpose of this bulletin is to inform the dealer network of a Safety Related Recall that affects specific Deliver 9 vehicles.

Service Managers are requested to ensure that all relevant staff are made aware of this information.

Please ensure ALL Vehicles presented to your Dealership have a campaign check carried out using menu option DC611 in the LDV Australia XT Dealer Connect Warranty System.

DETAILS

LDV Australia have identified a part supersession to the Low-Pressure Supply Line (TUBE-SPLY FUEL) which connects to the High-Pressure Fuel Pump on specific Deliver 9 vehicles.

There are 11,962 vehicles affected. A full VIN listed will be loaded onto the Dealer Portal.

The supersession change replaces the rubber style Low-Pressure Supply Line with a Low-Pressure Supply Line using a Quick Fit Connector. Refer to the required parts for more details.

LDV Australia is requesting Dealers to inspect affected Deliver 9 vehicles to ensure that the rubber style Low-Pressure Supply Line is not displaying any signs of deterioration as per outlined in the PROCESS section.

If a vehicle is presented with symptoms of the concern, the superseded tube must be fitted with the associated parts. Please note: a Technical Report will be required, and a separate warranty claim must be submitted.

PARTS REQUIRED

PART NO.	PART NAME	SEQUENCE	QUANTITY PER VIN
C00237593	TUBE-SPLY FUEL	ORIGINAL PART	1
C00566873	TUBE-SPLY FUEL	SUPERSEDED PART	1
C00525877	HIGH PRESSURE PUMP	SUPERSEDED PART	1
C00566514	BRACKET - WCAC	SUPERSEDED PART	1
C00211379	HEAT SHIELD OF CAM COVER	SUPERSEDED PART	1

PROCESS

NOTE: Remember to ensure the engine is cool before carrying out any repairs. Completing the repairs on a hot engine may result in a risk of injury/burns.

1. Inspect the area of concern which is located on the passenger side of the vehicle under the intercooler and above the high-pressure fuel pump.
2. Using both a mirror, physically check around the low-pressure supply line where it connects to the High-Pressure Fuel Pump, inspecting for any perforations, splits, weep or moisture coming from the low-pressure fuel line (Rubber hose section).

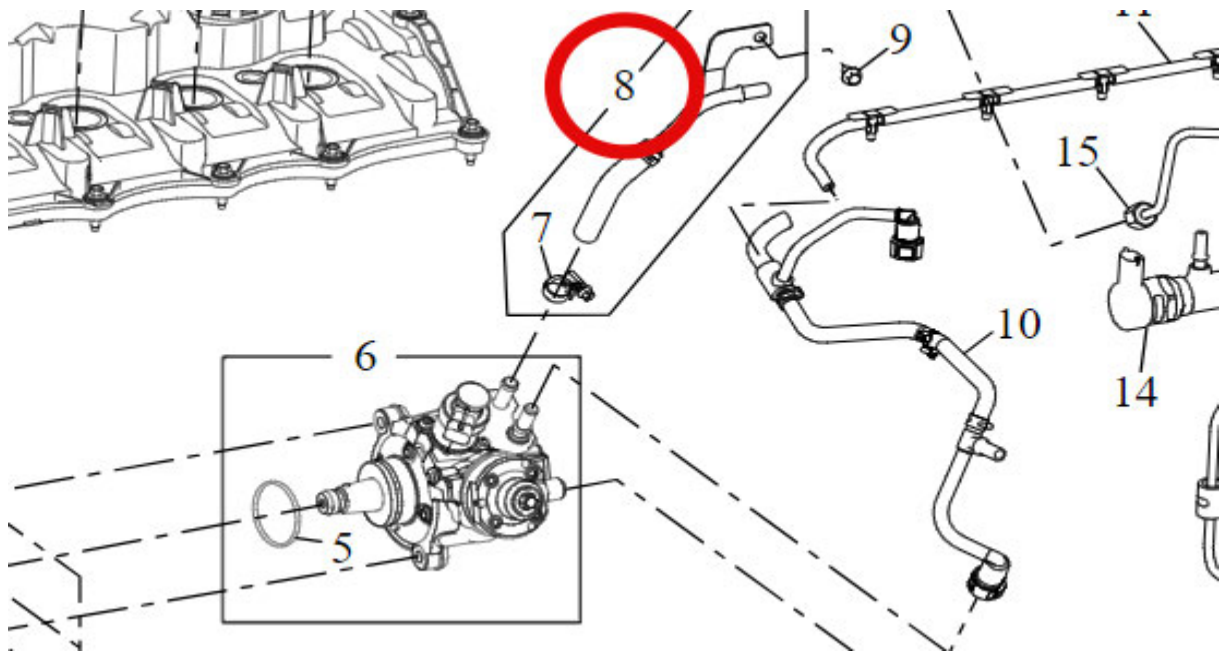

3. If any defects or concerns are identified in the above location, please carry out replacement of Low-Pressure Supply Lines and associated components. Once effected parts have been replaced (Fuel pump, Fuel lines and Bleed lines), wash down engine and carry out thorough test drive to ensure no leaks are evident.
4. If no signs of leaks are identified, finalise the inspection and claim the labour as per the Warranty Claim Submission details.

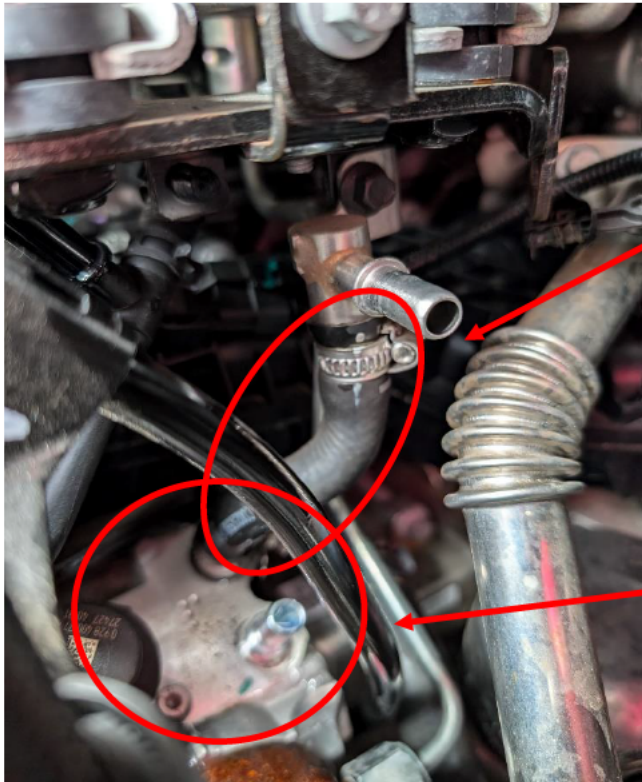

Inspect Fuel Line for perforations, cracking, looseness and defects.

Inspect for fuel seepage on fuel pump and cracking of low-pressure fuel line, this is a sign the fuel line may be compromised.

WARRANTY CLAIM SUBMISSION

Please submit your campaign claim via your Dealer Connect menu option DC603 using Service Campaign number LDV24##

Claim Entry | DC603

Service Campaign Number | LDV24##

Labour Code	Description	Labour Hours
CM11CI1201	LDV24## Hose ASM-FU RTN	0.4

Please contact your Aftersales Manager if you require any additional information or contact the Technical Hotline on (02) 8332 7775

Regards,

LDV Technical Support

LDV Automotive Australia



October 31, 2024

«FIRST_NAME» «SURNAME»
«COMPANY»
«ADDRESS»
«SUBURB» «STATE» «PC»

Dear Sir/Madam

RE: RAM RECALL CAMPAIGN LDV2437
VIN: «VIN»

As part of our Quality Assurance Procedures, LDV, the manufacturer of your vehicle, has advised that on some MY 19 to MY 23 LDV Deliver 9 vehicles, there may be a possibility of a manufacturing defect in the fuel supply line.

What are the defects?

The defect pertains to the low-pressure fuel supply line (TUBE-SPLY FUEL) that connects to the high-pressure fuel pump in specific LDV Deliver 9 vehicles. The original rubber-style fuel line may display signs of deterioration, such as perforations, splits, or moisture. LDV has identified this issue and has superseded the part with a new low-pressure supply line using a quick-fit connector to address these concerns.

What are the hazards?

If the low-pressure fuel line is compromised, it can lead to fuel seepage, which poses a risk of fuel leaks. This could potentially result in safety hazards such as engine performance issues, environmental concerns, or even fire hazards due to the presence of fuel leaks in the engine area.

What should consumers do?

Contact your authorised LDV dealer. For any additional information and assistance, please call LDV Customer Assist on 1800 716 894.

If you have sold your vehicle or have changed your address, we would appreciate it if you could advise us by completing and returning the form on the back of this letter.

Yours sincerely
National Service Department

LDV Australia
2A Hill Road
Lidcombe NSW 2141
Australia

Tel: +61 2 8577 8000
Fax: +61 2 8577 8199

ABN 34 000 486 706



Australian Government

**Department of Infrastructure, Transport,
Regional Development, Communications and the Arts**

REC-006165

Supplier contact details

**Title
First Name
Last Name
Date of Birth
Email Address
Mobile Phone
Home Phone
Work phone
Website**

s47F



Address Details

Address Type	Physical Address
Address Line 1	2A Hill Road
Town/Suburb	Lidcombe 2141
State/Territory/Province	NSW
Postcode/Zipcode	2141
Country	Australia

Address Type	Postal Address
Address Line 1	2A Hill Road
Town/Suburb	Lidcombe 2141
State/Territory/Province	NSW
Postcode/Zipcode	2141
Country	Australia

Recall contact details

Who is the contact for this recall?

Supplier as above

Recall overview

Your role in supplying the Approved Component

Importer

You are recalling:

Approved Component

Your campaign number for this recall: LDV2437

Approved Component details

Make and model and/or approval number for the Approved Component that is subject to this recall

Make: Other

LDV

Model: DELIVER 9

Approval number:

Variants that are subject to this recall:

All variants within this model

Date range of manufacture for the Approved Component subject to the recall

Date from	Date to
01/01/2021	31/12/2023

Recall details

Hazard (including the consequences of vehicle use in its non-compliant or unsafe state):

If the low-pressure fuel line is compromised, it can lead to fuel seepage, which poses a risk of fuel leaks. This could potentially result in safety hazards such as engine performance issues, environmental concerns, or even fire hazards due to the presence of fuel leaks in the engine area.

Defect (i.e. what is wrong)

The defect pertains to the low-pressure fuel supply line (TUBE-SPLY FUEL) that connects to the high-pressure fuel pump in specific LDV Deliver 9 vehicles. The original rubber-style fuel line may display signs of deterioration, such as perforations, splits, or moisture. LDV has identified this issue and has superseded the part with a new low-pressure supply line using a quick-fit connector to address these concerns.

Action (that owners/operators should take if they are in possession of the road vehicle of approved road vehicle component)

Consumers are advised to bring their affected Deliver 9 vehicles to an authorised dealer for inspection. Dealers will check the low-pressure fuel line for any signs of deterioration, such as perforations, cracks, or leaks. If any defects are found, the fuel line and associated components will be replaced under warranty. Consumers should follow up with their dealer to ensure the issue is resolved and take caution if they notice any fuel-related issues with their vehicle.

Who owners/operators should contact for more information

Contact name:

Contact phone number:

Contact email:

Website:

Non-compliance with standards

This recall action is NOT being taken on the basis that that there is non-compliance with the standards (to the best of your knowledge)

Comments

003. LDV2437 Bulletin_24 RC 002 LDV2437 Deliver 9 Low Pressure Fuel Line Inspection (002).pdf
004 Customer Letter - LDV2437.pdf

Do you consent to the publication of this recall notice on the department's website?

Yes

Additional recall details not provided yet.

From: s22(1)(a)(ii)
To: [RVR-VSO-Recalls](#)
Subject: FW: LDV RECALL- LDV2437 REC-006165) [SEC=OFFICIAL]
Date: Thursday, 31 October 2024 11:33:10 AM
Attachments: [image002.png](#)
[001. LDV2437 DIRD LDV.pdf](#)
[002. LDV2437 VIN List.csv](#)
[003. LDV2437 Bulletin 24 RC 002 LDV2437 Deliver 9 Low Pressure Fuel Line Inspection \(002\).pdf](#)
[004 Customer Letter - LDV2437.pdf](#)

OFFICIAL

Good morning Team,

Please see advice of recall lodged in Rover ([REC-006165](#)).

I have placed the original email in the Notifications Inbox.

Kind regards,

s22(1)
(a)(ii)

Senior Recalls Officer • Recalls Notification and Monitoring / Vehicle Safety Operations Branch •
 Road and Vehicle Safety Division
recalls@infrastructure.gov.au

Department of Infrastructure, Transport, Regional Development, Communications and the Arts
 CONNECTING AUSTRALIANS • ENRICHING COMMUNITIES • EMPOWERING REGIONS

infrastructure.gov.au



*I acknowledge the traditional custodians of this land on which we meet, work and live.
 I recognise and respect their continuing connection to the land, waters and communities.
 I pay my respects to Elders past and present and to all Aboriginal and Torres Strait Islander people.*

OFFICIAL

From: s47F <s47F@Ateco.com.au>
Sent: Thursday, 31 October 2024 11:22 AM
To: Recalls <Recalls@infrastructure.gov.au>
Cc: s47F <s47F@ateco.com.au>; s47F <s47F@ateco.com.au>; s47F <s47F@ateco.com.au>; s47F <s47F@ateco.com.au>; s47F <s47F@ateco.com.au>; s47F <s47F@ateco.com.au>; s47F <s47F@ateco.com.au>; s47F <s47F@ateco.com.au>; s47F <s47F@ateco.com.au>; s47F <s47F@ateco.com.au>
Subject: RE: LDV RECALL- LDV2437 REC-006165)

Good afternoon,

I am sharing files regarding the above-referenced recall with you.

These files are our letter to you, Dealer bulletin, draft customer letter and VIN list.

Please let me know if you have any questions.

Best Regards,

s47F

CUSTOMER RELATIONS MANAGER



2A Hill Rd Lidcombe NSW 2141 Australia

P s47F

E s47F [@ateco.com.au](mailto:s47F@ateco.com.au)

www.ateco.com.au

Please consider the environment before printing this e-mail.

IMPORTANT NOTICE: If this e-mail is received by other than the named addressee, please notify us immediately by telephone or return e-mail and delete all copies from your computer system. This document contains information proprietary to Ateco Group (Ateco Automotive Pty Ltd) and its affiliates or third parties to which Ateco may have a legal obligation to protect such information from unauthorised disclosure, use or duplication. Any disclosure, use or duplication of this document or the information contained herein for other than the specific purpose for which it was disclosed by Ateco is expressly prohibited. It is the recipient's responsibility to check this message and attachments for viruses.

 : **Please consider the environment before printing this e-mail.**

IMPORTANT NOTICE: If this e-mail is received by other than the named addressee, please notify us immediately by telephone or return e-mail and delete all copies from your computer system. This document contains information proprietary to Ateco Group and its affiliates or third parties to which Ateco may have a legal obligation to protect such information from unauthorised disclosure, use or duplication. Any disclosure, use or duplication of this document or the information contained herein for other than the specific purpose for which it was disclosed by Ateco is expressly prohibited. It is the recipient's responsibility to check this message and attachments for viruses.



October 31, 2024

Director
Operational Policy, Risk and Compliance Section
Department of Infrastructure and Regional Development
GPO Box 594
Canberra ACT 2601

Dear Sir

RE: LDV AUSTRALIA PTY LTD - SAFETY RECALL CAMPAIGN – LDV2437

We would like to inform you that on October 31, 2024, we will officially initiate Safety Recall Campaign LDV2437.

In accordance with the Code of Practice, we hereby forward to you the campaign details, which are as follows:

1. Target vehicles are 11,963.
2. Our initial contact with the owners will be by mail. The mail-out will be conducted by our organisation. We also provide a Customer Assistance telephone number (1800 716 894) to give advice to our customers.
3. Follow-up will be made in accordance with the 90-day period specified in the Code and as necessary, we will pursue owner details via the registration authorities (but as we expect completion within 60 days, this and public advertising may not be necessary).
4. The campaign details for your information and publication on the recall website and on the schedule are given on Page 2 of this letter.
5. Ample parts and material provisions have been made and we are fully capable of discharging this campaign completely, in accordance with customer response.
6. The Dealer Principal and Service Manager of each Dealership have been provided with a list of vehicles sold by their organisation as well as the full listing of vehicles involved and have been instructed to also make telephone contact with all their customers.

If you require further information, please do not hesitate to contact the undersigned.

Yours sincerely

National Service Department

LDV Australia
2A Hill Road
Lidcombe NSW 2141
Australia

Tel: +61 2 8577 8000
Fax: +61 2 8577 8199

ABN 34 000 486 706



LDV

LDV AUSTRALIA - SAFETY RECALL CAMPAIGN – LDV2437

LDV DELIVER 9

MY19 to MY23

Date: October 31, 2024

Supplier: LDV Australia Pty Ltd

Category: Motor Vehicles

Product Info: Safety Recall Campaign LDV2437

Defect Details: The defect pertains to the low-pressure fuel supply line (TUBE-SPLY FUEL) that connects to the high-pressure fuel pump in specific LDV Deliver 9 vehicles. The original rubber-style fuel line may display signs of deterioration, such as perforations, splits, or moisture. LDV has identified this issue and has superseded the part with a new low-pressure supply line using a quick-fit connector to address these concerns.

Consequences: If the low-pressure fuel line is compromised, it can lead to fuel seepage, which poses a risk of fuel leaks. This could potentially result in safety hazards such as engine performance issues, environmental concerns, or even fire hazards due to the presence of fuel leaks in the engine area.

Corrective Action: Consumers are advised to bring their affected Deliver 9 vehicles to an authorised dealer for inspection. Dealers will check the low-pressure fuel line for any signs of deterioration, such as perforations, cracks, or leaks. If any defects are found, the fuel line and associated components will be replaced under warranty. Consumers should follow up with their dealer to ensure the issue is resolved and take caution if they notice any fuel-related issues with their vehicle.

Consumer Action: Contact your authorised LDV dealer. For any additional information and assistance, please call LDV Customer Assist on 1800 716 894.

Make: LDV

Models: DELIVER 9 MY19 to MY23

Campaign Number: LDV2437

Market Coverage: National

Recall Coverage: National

LDV Australia
2A Hill Road
Lidcombe NSW 2141
Australia

Tel: +61 2 8577 8000
Fax: +61 2 8577 8199

ABN 34 000 486 706

From: s22(1)(a)(ii)
To: s22(1)(a)(ii)
Cc: s22(1)(a)(ii)
Subject: RE: Notification Notices for Review [SEC=OFFICIAL]
Date: Tuesday, 5 November 2024 11:14:41 AM
Attachments: [image001.png](#)
 s22(1)(a)(ii)
[REC-006165 - ATECO LDV- Notification Notice.docx](#)
 s22(1)(a)(ii)

OFFICIAL

Good Morning s22(1)

s22(1)(a)(ii)
 s22(1)(a)(ii)
 s22(1)(a)(ii)
 s22(1)(a)(ii)
 s22(1)(a)(ii)
 s22(1)(a)(ii)

165 – amendments in track

s22(1)(a)(ii)
 s22(1)(a)(ii)

Happy to discuss.

Thanks for a big effort with these.

s22(1)(a)(ii)

s22(1)(a)(ii)

Director • Recalls Notification and Monitoring/ Vehicle Safety Operations Branch • Road and Vehicle Safety Division

s22(1)(a)(ii) [@infrastructure.gov.au](#)

P s22(1)(a)(ii) • M s22(1)(a)(ii)

GPO Box 594 Canberra, ACT 2601

Department of Infrastructure, Transport, Regional Development, Communications and the Arts

CONNECTING AUSTRALIANS • ENRICHING COMMUNITIES • EMPOWERING REGIONS

[infrastructure.gov.au](#)



*I would like to acknowledge the traditional custodians of this land on which we meet, work and live.
 I recognise and respect their continuing connection to the land, waters and communities.
 I pay my respects to Elders past and present and to all Aboriginal and Torres Strait Islanders.*

OFFICIAL

From: s22(1)(a)(ii) <s22(1)(a)(ii)@infrastructure.gov.au>

Released under the FOI Act 1982 by the Department of Infrastructure, Transport, Regional Development, Communications, Sport and the Arts

Sent: Monday, 4 November 2024 9:07 AM

To: s22(1)(a)(ii) <s22(1)(a)(ii)@infrastructure.gov.au>

Subject: Notification Notices for Review [SEC=OFFICIAL]

OFFICIAL

Hi s22(1)(a)(ii),

I put all the notifications notices to review in on email

s22(1)(a)(ii)

s22(1)(a)(ii)

s22(1)(a)(ii)

s22(1)(a)(ii)

s22(1)(a)(ii)

s22(1)(a)(ii)

REC-006165-Ateco

s22(1)(a)(ii)

s22(1)(a)(ii)

Cheers

s22(1)

OFFICIAL

Released under the FOI Act 1982 by the Department of Infrastructure, Transport, Regional Development, Communications, Sport and the Arts

What are the defects?

Department Suggestion

Due to a manufacturing defect, the low-pressure fuel delivery line may not meet specifications. As a result, it may deteriorate allowing fuel to leak. A fuel leak in the presence of an external ignition source could result in a vehicle fire.

Supplier notification

The defect pertains to the low-pressure fuel supply line (TUBE-SPLY FUEL) that connects to the high-pressure fuel pump in specific LDV Deliver 9 vehicles. The original rubber-style fuel line may display signs of deterioration, such as perforations, splits, or moisture. LDV has identified this issue and has superseded the part with a new low-pressure supply line using a quick-fit connector to address these concerns.

What are the hazards?

Department Suggestion

A vehicle fire could cause injury or death to vehicle occupants, other road users or bystanders and/or damage to property.

Supplier notification

If the low-pressure fuel line is compromised, it can lead to fuel seepage, which poses a risk of fuel leaks. This could potentially result in safety hazards such as engine performance issues, environmental concerns, or even fire hazards due to the presence of fuel leaks in the engine area.

What should consumers do?

Department Suggestion

Owners of affected vehicles should contact their local authorised LDV dealer to make an appointment to have the vehicle inspected and fuel line replaced, free of charge.

Supplier notification

Consumers are advised to bring their affected Deliver 9 vehicles to an authorised dealer for inspection. Dealers will check the low-pressure fuel line for any signs of deterioration, such as perforations, cracks, or leaks. If any defects are found, the fuel line and associated components will be replaced under warranty. Consumers should follow up with their dealer to ensure the issue is resolved and take caution if they notice any fuel-related issues with their vehicle.



Australian Government

Department of Infrastructure, Transport, Regional Development, Communications and the Arts

Recall Notice

Recall number: REC-006165

Campaign number LDV2437

First published:

Last updated:

Make: Other

LDV

Model DELIVER 9

Variant All variants within this model

Year range

Date from	Date to
01/01/2021	31/12/2023

Affected units 11962

What are the defects?

Due to a manufacturing defect, the low-pressure fuel delivery line may not meet specifications. As a result, it may deteriorate allowing fuel to leak. A fuel leak in the presence of an external ignition source could result in a vehicle fire.

What are the hazards?

A vehicle fire could cause injury or death to vehicle occupants, other road users or bystanders and/or damage to property.

What should consumers do?

Owners of affected vehicles should contact their local authorised LDV dealer to make an appointment to have the vehicle inspected and fuel line replaced, free of charge.

Supplier details ATECO AUTOMOTIVE PTY LIMITED

Who should owners/operators contact for more information?

LDV Dealer

1800 716 894

Responsible regulator DITRDC

Product type Approved Component

From: s22(1)(a)(ii)
To: s47F ; s47F ; s47F
Cc: s47F
Subject: RE: REC-006165 s22(1)(a)(ii) Revised Wordings [SEC=OFFICIAL]
Date: Friday, 8 November 2024 1:55:20 PM
Attachments: [image003.png](#)
[image005.png](#)

OFFICIAL

Thank you s47F
 Amended and published.
 Have a nice weekend everyone.
 Cheers
 s22(1)(a)(ii)

Senior Recalls Officer • Recalls Notification and Monitoring • Vehicle Safety Operations Branch • Road and Vehicle Safety Division

s22(1)(a) [@infrastructure.gov.au](#)
 P s22(1)(a)(ii)

GPO Box 594 Canberra, ACT 2601

Department of Infrastructure, Transport, Regional Development, Communications and the Arts

CONNECTING AUSTRALIANS • ENRICHING COMMUNITIES • EMPOWERING REGIONS

[infrastructure.gov.au](#)



I would like to acknowledge the traditional custodians of this land on which we meet, work and live. I recognise and respect their continuing connection to the land, waters and communities. I pay my respects to Elders past and present and to all Aboriginal and Torres Strait Islanders.

OFFICIAL

From: s47F
Sent: Friday, 8 November 2024 1:34 PM
To: s47F ; s22(1)(a)(ii) ; s47F
Cc: s47F
Subject: RE: REC-006165 s22(1)(a)(ii) Revised Wordings [SEC=OFFICIAL]

Hi s47F,

Rider should be removed and replaced with Driver

What are the hazards?

If the turn signal indicators do not operate as intended, other road users may be unable to identify if the vehicle is turning. This could increase the risk of an accident causing serious injury or death to the **rider** and/or other road users.

Kind Regards.

s47F

National Service Manager



2A Hill Rd Lidcombe NSW 2141 Australia

P s47F | M s47F

E s47F @ateco.com.au

[www.ramtrucks.com.au](#)

IMPORTANT NOTICE: If this e-mail is received by other than the named addressee, please notify us immediately by telephone or return e-mail and delete all copies from your computer system. This document contains information proprietary to Ateco Group (Ateco Automotive Pty Ltd) and its

affiliates or third parties to which Ateco may have a legal obligation to protect such information from unauthorised disclosure, use or duplication. Any disclosure, use or duplication of this document or the information contained herein for other than the specific purpose for which it was disclosed by Ateco is expressly prohibited. It is the recipient's responsibility to check this message and attachments for viruses.

From: s47F <s47F@ateco.com.au>
Sent: Friday, 8 November 2024 10:55 AM
To: s22(1)(a)(ii) <s22(1)(a)(ii)@infrastructure.gov.au>; s47F <s47F@ateco.com.au>; s47F <s47F@ateco.com.au>
Cc: s47F <s47F@ateco.com.au>
Subject: RE: REC-006165 & REC-006167 Revised Wordings [SEC=OFFICIAL]

Hi s47F and s47F,

Could you both review the wording below for these two recalls and let s22(1)(a) know if you're satisfied with it and if it can be published?

REC-006165 (LDV2437)

s22(1)(a)(ii)

What are the defects?

Due to a software issue in the steering column control module (SCCM), the turn signal lever may not cancel when the steering wheel is rotated or switched off manually. This could lead to a non-cancelling indicator and/or high beams activating.

What are the hazards?

If the turn signal indicators do not operate as intended, other road users may be unable to identify if the vehicle is turning. This could increase the risk of an accident causing serious injury or death to the rider and/or other road users.

What should consumers do?

Owners of affected vehicles should contact their local authorised RAM dealer to inspect and replace SCCM if necessary, free of charge.

And

What are the defects?

Due to a manufacturing defect, the low-pressure fuel delivery line may not meet specifications. As a result, it may deteriorate allowing fuel to leak. A fuel leak in the presence of an external ignition source could result in a vehicle fire.

What are the hazards?

A vehicle fire could cause injury or death to vehicle occupants, other road users or bystanders and/or damage to property.

What should consumers do?

Owners of affected vehicles should contact their local authorised LDV dealer to make an appointment to have the vehicle inspected and fuel line replaced, free of charge.

Best Regards,

s47F

CUSTOMER RELATIONS MANAGER

 **ATECO GROUP**

2A Hill Rd Lidcombe NSW 2141 Australia

P s47F

E s47F@ateco.com.au

www.ateco.com.au

Please consider the environment before printing this e-mail.

IMPORTANT NOTICE: If this e-mail is received by other than the named addressee, please notify us immediately by telephone or return e-mail and delete all copies from your computer system. This document contains information proprietary to Ateco Group (Ateco Automotive Pty Ltd) and its affiliates or third parties to which Ateco may have a legal obligation to protect such information from unauthorised disclosure, use or duplication. Any disclosure, use or duplication of this document or the information contained herein for other than the specific purpose for which it was disclosed by Ateco is expressly prohibited. It is the recipient's responsibility to check this message and attachments for viruses.

From: s22(1)(a)(ii) <s22(1)(a)(ii)@infrastructure.gov.au>

Sent: Wednesday, November 6, 2024 9:30 AM

To: s47F <s47F@ateco.com.au>

Subject: REC-006165 & REC-006167 Revised Wordings [SEC=OFFICIAL]

OFFICIAL

Hi s47F,

I send you below revised wordings to review through ROVER.

Please see below the draft recall notification notice for your review. Please have a look over it and let me know if you're happy with the wording or would like any changes made?

What are the defects?

Due to a software issue in the steering column control module (SCCM), the turn signal lever may not cancel when the steering wheel is rotated or switched off manually. This could lead to a non-cancelling indicator and/or high beams activating.

What are the hazards?

If the turn signal indicators do not operate as intended, other road users may be unable to identify if the vehicle is turning. This could increase the risk of an accident causing serious injury or death to the rider and/or other road users.

What should consumers do?

Owners of affected vehicles should contact their local authorised RAM dealer to inspect and replace SCCM if necessary, free of charge.

And

What are the defects?

Due to a manufacturing defect, the low-pressure fuel delivery line may not meet specifications. As a result, it may deteriorate allowing fuel to leak. A fuel leak in the presence of an external ignition source could result in a vehicle fire.

What are the hazards?

A vehicle fire could cause injury or death to vehicle occupants, other road users or bystanders and/or damage to property.

What should consumers do?

Owners of affected vehicles should contact their local authorised LDV dealer to make an appointment to have the vehicle inspected and fuel line replaced, free of charge.

Cheers

s22(1)(a)(ii)

Senior Recalls Officer • Recalls Notification and Monitoring • Vehicle Safety Operations Branch • Road and Vehicle Safety Division

s22(1)(a) @infrastructure.gov.au

P s22(1)(a)(ii)

GPO Box 594 Canberra, ACT 2601

Department of Infrastructure, Transport, Regional Development, Communications and the Arts

CONNECTING AUSTRALIANS • ENRICHING COMMUNITIES • EMPOWERING REGIONS

infrastructure.gov.au



I would like to acknowledge the traditional custodians of this land on which we meet, work and live. I recognise and respect their continuing connection to the land, waters and communities. I pay my respects to Elders past and present and to all Aboriginal and Torres Strait Islanders.

Sali

OFFICIAL

Disclaimer

This message has been issued by the Department of Infrastructure, Transport, Regional Development, Communications and the Arts. The information transmitted is for the use of the intended recipient only and may contain confidential and/or legally privileged material. Any review, re-transmission, disclosure, dissemination or other use of, or taking of any action in reliance upon, this information by persons or entities other than the intended recipient is prohibited and may result in severe penalties.

If you have received this e-mail in error, please notify the Department on +61 (2) 6274 7111 and delete all copies of this transmission together with any attachments.

 : *Please consider the environment before printing this e-mail.*

IMPORTANT NOTICE: If this e-mail is received by other than the named addressee, please notify us immediately by telephone or return e-mail and delete all copies from your computer system. This document contains information proprietary to Ateco Group and its affiliates or third parties to which Ateco may have a legal obligation to protect such information from unauthorised disclosure, use or duplication. Any disclosure, use or duplication of this document or the information contained herein for other than the specific purpose for which it was disclosed by Ateco is expressly prohibited. It is the recipient's responsibility to check this message and attachments for viruses.

From: s47F
To: s22(1), s47F
Cc: s47F, s47F, s47F
Subject: RE: REC-006165 & REC-006167 Revised Wordings recall LDV2437 [SEC=OFFICIAL]
Date: Wednesday, 30 April 2025 10:38:11 AM
Attachments: image004.png

That's perfect, thank you so much, s22

Have a lovely day!

Best Regards,

s47F
CUSTOMER RELATIONS MANAGER



2A Hill Rd Lidcombe NSW 2141 Australia

P s47F
E s47F@ateco.com.au

www.ateco.com.au

Please consider the environment before printing this e-mail.

IMPORTANT NOTICE: If this e-mail is received by other than the named addressee, please notify us immediately by telephone or return e-mail and delete all copies from your computer system. This document contains information proprietary to Ateco Group (Ateco Automotive Pty Ltd) and its affiliates or third parties to which Ateco may have a legal obligation to protect such information from unauthorised disclosure, use or duplication. Any disclosure, use or duplication of this document or the information contained herein for other than the specific purpose for which it was disclosed by Ateco is expressly prohibited. It is the recipient's responsibility to check this message and attachments for viruses.

From: s22(1) <s22(1)@infrastructure.gov.au>
Sent: Wednesday, April 30, 2025 8:33 AM
To: s47F <s47F@ateco.com.au>; s47F <s47F@ateco.com.au>
Cc: s47F <s47F@ateco.com.au>; s47F <s47F@ateco.com.au>; s47F <s47F@ateco.com.au>; s47F <s47F@ateco.com.au>
Subject: RE: REC-006165 s22(1)(a) Revised Wordings recall LDV2437 [SEC=OFFICIAL]

OFFICIAL

Hi s47F,

I had a nice break thank you for asking.

I've changed the wordings for both recalls as below:

Owners of affected vehicles should contact their local authorised LDV dealer to make an appointment to have the vehicle inspected and if necessary fuel line replaced, free of charge.

It should appear on the website tomorrow morning.

Cheers

s22(1)(a)(ii)

Senior Recalls Officer • Recalls Notification and Monitoring • Vehicle Safety Operations Branch • Road and Vehicle Safety Division

s22(1)@infrastructure.gov.au

P s22(1)(a)

GPO Box 594 Canberra, ACT 2601

Department of Infrastructure, Transport, Regional Development, Communications and the Arts
CONNECTING AUSTRALIANS • ENRICHING COMMUNITIES • EMPOWERING REGIONS

infrastructure.gov.au



I would like to acknowledge the traditional custodians of this land on which we meet, work and live. I recognise and respect their continuing connection to the land, waters and communities. I pay my respects to Elders past and present and to all Aboriginal and Torres Strait Islanders.

OFFICIAL

From: s47F <s47F@ateco.com.au>
Sent: Tuesday, 29 April 2025 6:36 PM
To: s22(1) <s22(1)@infrastructure.gov.au>; s47F <s47F@ateco.com.au>
Cc: s47F <s47F@ateco.com.au>; s47F <s47F@ateco.com.au>; s47F <s47F@ateco.com.au>; s47F <s47F@ateco.com.au>
Subject: RE: REC-006165 s22(1)(a) Revised Wordings [SEC=OFFICIAL] recall LDV2437

Hi s2,

I hope you're well and had a lovely Easter break.

May I please request a review of the below?

It looks like there's an error in the wording below. The fuel line is not automatically required to be replaced — it's a two-part process: first, an

inspection is carried out, and only if necessary, the fuel line is replaced. However, the way it's currently worded has lead consumers to believe that the fuel line will be replaced regardless of the inspection outcome.

Could you please update the website accordingly? At the moment, customers are expecting a replacement even when it may not be necessary.

What should consumers do?

Owners of affected vehicles should contact their local authorised LDV dealer to make an appointment to have the vehicle inspected and fuel line replaced if necessary, free of charge.

What are the defects?

Due to a manufacturing defect, the low-pressure fuel delivery line may not meet specifications. As a result, it may deteriorate allowing fuel to leak. A fuel leak in the presence of an external ignition source could result in a vehicle fire.

What are the hazards?

A vehicle fire could cause injury or death to vehicle occupants, other road users or bystanders and/or damage to property.

What should consumers do?

Owners of affected vehicles should contact their local authorised LDV dealer to make an appointment to have the vehicle inspected and fuel line replaced, free of charge.

Thank you

Best Regards,

s47F
CUSTOMER RELATIONS MANAGER



2A Hill Rd Lidcombe NSW 2141 Australia

P s47F
E s47F@ateco.com.au
www.ateco.com.au

Please consider the environment before printing this e-mail.

IMPORTANT NOTICE: If this e-mail is received by other than the named addressee, please notify us immediately by telephone or return e-mail and delete all copies from your computer system. This document contains information proprietary to Ateco Group (Ateco Automotive Pty Ltd) and its affiliates or third parties to which Ateco may have a legal obligation to protect such information from unauthorised disclosure, use or duplication. Any disclosure, use or duplication of this document or the information contained herein for other than the specific purpose for which it was disclosed by Ateco is expressly prohibited. It is the recipient's responsibility to check this message and attachments for viruses.

From S <s22(1)@infrastructure.gov.au>
Sent: Friday, November 8, 2024 12:32 PM
To: s47F <s47F@ateco.com.au>; s47F <s47F@ateco.com.au>; s47F <s47F@ateco.com.au>
Cc: s47F <s47@ateco.com.au>
Subject: RE: REC-006165 s22(1)(a) Revised Wordings [SEC=OFFICIAL]

OFFICIAL

Thank you s4

REC-006165 has now been published and it will appear on the Recalls website tomorrow morning.

Cheers

s2

OFFICIAL

From: s47F <s47F@ateco.com.au>
Sent: Friday, 8 November 2024 12:28 PM
To: s47F <s47F@ateco.com.au>; s22(1) <s22(1)@infrastructure.gov.au>; s47F <s47F@ateco.com.au>
Cc: s47F <s47@ateco.com.au>
Subject: RE: REC-006165 s22(1)(a) Revised Wordings [SEC=OFFICIAL]

Hi s4,

I'm OK with the suggested changes for the LDV recall.

s47F
National Service Manager – LDV



2A Hill Road Lidcombe NSW 2141 Australia

P s47F | M s47F
E s47F@ateco.com.au

www.ateco.com.au

From: s47F <s47F@ateco.com.au>
Sent: Friday, November 8, 2024 10:55 AM
To: s22(1) <s22(1)@infrastructure.gov.au>; s47F <s47F@ateco.com.au>; s47F <s47F@ateco.com.au>
Cc: s47F <s47F@ateco.com.au>
Subject: RE: REC-006165 s22(1)(a) Revised Wordings [SEC=OFFICIAL]

Hi s47 and s47,

Could you both review the wording below for these two recalls and let Sali know if you're satisfied with it and if it can be published?

REC-006165 (LDV2437)
 s22(1)(a)(ii)

What are the defects?

Due to a software issue in the steering column control module (SCCM), the turn signal lever may not cancel when the steering wheel is rotated or switched off manually. This could lead to a non-cancelling indicator and/or high beams activating.

What are the hazards?

If the turn signal indicators do not operate as intended, other road users may be unable to identify if the vehicle is turning. This could increase the risk of an accident causing serious injury or death to the rider and/or other road users.

What should consumers do?

Owners of affected vehicles should contact their local authorised RAM dealer to inspect and replace SCCM if necessary, free of charge.

And

What are the defects?

Due to a manufacturing defect, the low-pressure fuel delivery line may not meet specifications. As a result, it may deteriorate allowing fuel to leak. A fuel leak in the presence of an external ignition source could result in a vehicle fire.

What are the hazards?

A vehicle fire could cause injury or death to vehicle occupants, other road users or bystanders and/or damage to property.

What should consumers do?

Owners of affected vehicles should contact their local authorised LDV dealer to make an appointment to have the vehicle inspected and fuel line replaced, free of charge.

Best Regards,

s47F
 CUSTOMER RELATIONS MANAGER

 **ATECO GROUP**

2A Hill Rd Lidcombe NSW 2141 Australia

P s47F
 E s47F@ateco.com.au
www.ateco.com.au

Please consider the environment before printing this e-mail.

IMPORTANT NOTICE: If this e-mail is received by other than the named addressee, please notify us immediately by telephone or return e-mail and delete all copies from your computer system. This document contains information proprietary to Ateco Group (Ateco Automotive Pty Ltd) and its affiliates or third parties to which Ateco may have a legal obligation to protect such information from unauthorised disclosure, use or duplication. Any disclosure, use or duplication of this document or the information contained herein for other than the specific purpose for which it was disclosed by Ateco is expressly prohibited. It is the recipient's responsibility to check this message and attachments for viruses.

From: s22(1) <s22(1)@infrastructure.gov.au>
Sent: Wednesday, November 6, 2024 9:30 AM
To: s47F <s47F@ateco.com.au>
Subject: REC-006165 s22(1)(a) Revised Wordings [SEC=OFFICIAL]

OFFICIAL

Hi s47F,

I sent the two below revised wordings to review through ROVER.

Please see below the draft recall notification notice for your review. Please have a look over it and let me know if you're happy with the wording or would like any changes made?

What are the defects?

Due to a software issue in the steering column control module (SCCM), the turn signal lever may not cancel when the steering wheel is rotated or switched off manually. This could lead to a non-cancelling indicator and/or high beams activating.

What are the hazards?

If the turn signal indicators do not operate as intended, other road users may be unable to identify if the vehicle is turning. This could increase the risk of an accident causing serious injury or death to the rider and/or other road users.

What should consumers do?

Owners of affected vehicles should contact their local authorised RAM dealer to inspect and replace SCCM if necessary, free of charge.

And

What are the defects?

Due to a manufacturing defect, the low-pressure fuel delivery line may not meet specifications. As a result, it may deteriorate allowing fuel to leak. A fuel leak in the presence of an external ignition source could result in a vehicle fire.

What are the hazards?

A vehicle fire could cause injury or death to vehicle occupants, other road users or bystanders and/or damage to property.

What should consumers do?

Owners of affected vehicles should contact their local authorised LDV dealer to make an appointment to have the vehicle inspected and fuel line replaced, free of charge.

Cheers

s22(1)(a)(ii)

Senior Recalls Officer • Recalls Notification and Monitoring • Vehicle Safety Operations Branch • Road and Vehicle Safety Division

[s22\(1\)@infrastructure.gov.au](mailto:s22(1)@infrastructure.gov.au)

s22(1)(a)

GPO Box 594 Canberra, ACT 2601

Department of Infrastructure, Transport, Regional Development, Communications and the Arts

CONNECTING AUSTRALIANS • ENRICHING COMMUNITIES • EMPOWERING REGIONS

infrastructure.gov.au



I would like to acknowledge the traditional custodians of this land on which we meet, work and live. I recognise and respect their continuing connection to the land, waters and communities. I pay my respects to Elders past and present and to all Aboriginal and Torres Strait Islanders.

s2

2(

OFFICIAL

Disclaimer

This message has been issued by the Department of Infrastructure, Transport, Regional Development, Communications and the Arts. The information transmitted is for the use of the intended recipient only and may contain confidential and/or legally privileged material. Any review, re-transmission, disclosure, dissemination or other use of, or taking of any action in reliance upon, this information by persons or entities other than the intended recipient is prohibited and may result in severe penalties. If you have received this e-mail in error, please notify the Department on +61 (2) 6274 7111 and delete all copies of this transmission together with any attachments.

: Please consider the environment before printing this e-mail.

IMPORTANT NOTICE: If this e-mail is received by other than the named addressee, please notify us immediately by telephone or return e-mail and delete all copies from your computer system. This document contains information proprietary to Alteo Group and its affiliates or third parties to which Alteo may have a legal obligation to protect such information from unauthorised disclosure, use or duplication. Any disclosure, use or duplication of this document or the information contained herein for other than the specific purpose for which it was disclosed by Alteo is expressly prohibited. It is the recipient's responsibility to check this message and attachments for viruses.

Disclaimer

This message has been issued by the Department of Infrastructure, Transport, Regional Development, Communications and the Arts. The information transmitted is for the use of the intended recipient only and may contain confidential and/or legally privileged material. Any review, re-transmission, disclosure, dissemination or other use of, or taking of any action in reliance upon, this information by persons or entities other than the intended recipient is prohibited and may result in severe penalties. If you have received this e-mail in error, please notify the Department on +61 (2) 6274 7111 and delete all copies of this transmission together with any attachments.

: Please consider the environment before printing this e-mail.

IMPORTANT NOTICE: If this e-mail is received by other than the named addressee, please notify us immediately by telephone or return e-mail and delete all copies from your computer system. This document contains information proprietary to Alteo Group and its affiliates or third parties to which Alteo may have a legal obligation to protect such information from unauthorised disclosure, use or duplication. Any disclosure, use or duplication of this document or the information contained herein for other than the specific purpose for which it was disclosed by Alteo is expressly prohibited. It is the recipient's responsibility to check this message and attachments for viruses.

Disclaimer

This message has been issued by the Department of Infrastructure, Transport, Regional Development, Communications and the Arts. The information transmitted is for the use of the intended recipient only and may contain confidential and/or legally privileged material. Any review, re-transmission, disclosure, dissemination or other use of, or taking of any action in reliance upon, this information by persons or entities other than the intended recipient is prohibited and may result in severe penalties. If you have received this e-mail in error, please notify the Department on +61 (2) 6274 7111 and delete all copies of this transmission together with any

attachments.

 : Please consider the environment before printing this e-mail.

IMPORTANT NOTICE: If this e-mail is received by other than the named addressee, please notify us immediately by telephone or return e-mail and delete all copies from your computer system. This document contains information proprietary to Ateco Group and its affiliates or third parties to which Ateco may have a legal obligation to protect such information from unauthorised disclosure, use or duplication. Any disclosure, use or duplication of this document or the information contained herein for other than the specific purpose for which it was disclosed by Ateco is expressly prohibited. It is the recipient's responsibility to check this message and attachments for viruses.

From: s47F
To: Recalls; s47F
Subject: RE: Request to submit Recall Report [SEC=OFFICIAL]
Date: Friday, 2 May 2025 4:43:03 PM
Attachments: image002.png
 image003.png

Good afternoon s22(1) ,

Please accept my apologies for not submitting reports for recalls REC-006165, s22(1)(a)(ii) . I have made a note, and these recalls will be on the Bulk Progress Report moving forward.

Regards,

s47F



2A Hill Rd Lidcombe NSW 2141 Australia

From: Recalls <Recalls@infrastructure.gov.au>
Sent: Monday, 28 April 2025 1:55 PM
To: s47F s47F @ateco.com.au>; s47F s47F @ateco.com.au>; s47F <s47F @ateco.com.au>
Cc: Recalls <Recalls@infrastructure.gov.au>
Subject: Request to submit Recall Report [SEC=OFFICIAL]

OFFICIAL

Good afternoon Team

I hope this email finds you well.

As part of its regulatory activities, the Department of Infrastructure, Transport, Regional Development, Communications and the Arts (the department) is responsible for administering the framework for the recall of road vehicles and approved road vehicle components that are unsafe or do not comply with applicable standards. This includes monitoring the progress of recall campaigns undertaken by Suppliers to ensure effective rectification of unsafe or non-compliant vehicles or components.

To determine if satisfactory action is being taken on active recalls, the Department considers the progress reports submitted by Suppliers through [ROVER](#). During our regular monitoring, we identified the below recall that has not had any reports submitted for three or more consecutive months.

Recall	Last Report Submitted	Supplier
REC-006165		ATECO AUTOMOTIVE PTY LIMITED
s22(1)(a)(ii)		s22(1)(a)(ii)
s22(1)(a)(ii)		s22(1)(a)(ii)

In order for the Department to determine the current progress of your recall, you will need to submit this report under the reporting feature within [ROVER](#). Please have this report submitted as a priority by COB **5 May 2025**, to avoid any further escalation of the matter.

If you are unable to submit this report, please advise the reason for this or advise how we can assist. Alternatively, please do not hesitate to contact us via return email if you have any questions.

s22(1)

(a)
Senior Recalls Officer • Recalls Notification and Monitoring / Vehicle Safety Operations Branch • Road and Vehicle Safety
Division
Recalls@infrastructure.gov.au

Department of Infrastructure, Transport, Regional Development, Communications and the Arts
CONNECTING AUSTRALIANS • ENRICHING COMMUNITIES • EMPOWERING REGIONS

infrastructure.gov.au   

*I acknowledge the traditional custodians of this land on which we meet, work and live.
I recognise and respect their continuing connection to the land, waters and communities.
I pay my respects to Elders past and present and to all Aboriginal and Torres Strait Islander people.*

OFFICIAL

Disclaimer

This message has been issued by the Department of Infrastructure, Transport, Regional Development, Communications and the Arts. The information transmitted is for the use of the intended recipient only and may contain confidential and/or legally privileged material.

Any review, re-transmission, disclosure, dissemination or other use of, or taking of any action in reliance upon, this information by persons or entities other than the intended recipient is prohibited and may result in severe penalties.

If you have received this e-mail in error, please notify the Department on +61 (2) 6274 7111 and delete all copies of this transmission together with any attachments.

 : Please consider the environment before printing this e-mail.

IMPORTANT NOTICE: If this e-mail is received by other than the named addressee, please notify us immediately by telephone or return e-mail and delete all copies from your computer system. This document contains information proprietary to Ateco Group and its affiliates or third parties to which Ateco may have a legal obligation to protect such information from unauthorised disclosure, use or duplication. Any disclosure, use or duplication of this document or the information contained herein for other than the specific purpose for which it was disclosed by Ateco is expressly prohibited. It is the recipient's responsibility to check this message and attachments for viruses.