

Section F

SUSPENSION

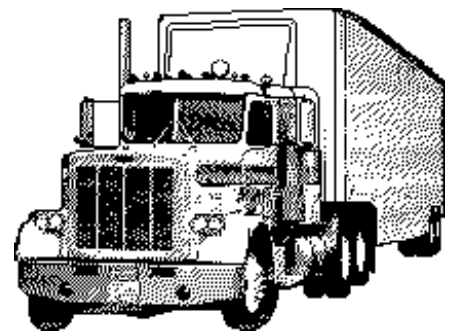
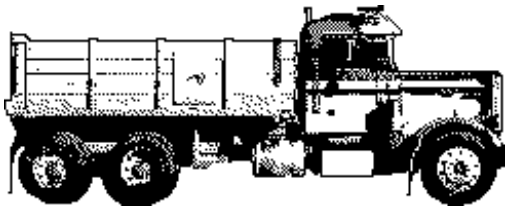

HEAVY VEHICLE MODIFICATIONS**SUSPENSION SUBSTITUTION****1. SCOPE**

This Section relates to the fitting of modified suspensions to heavy vehicles.

It outlines the minimum requirements for heavy vehicle suspension modifications and includes the fitting of substitute suspensions.

2. GENERAL INFORMATION

This Section collates the requirements of a number of different modifications to vehicle suspension. Each modification type is sufficiently different from the others that all data relating to that modification should be grouped together. Accordingly, each modification type is treated as a stand alone Modification Code.

3. ADR's AFFECTED

Some ADR's are affected by a suspension modification. Care must be exercised to ensure that any ADR which is incidentally affected - e.g. ADR 35/..; *Heavy Vehicle Brake Systems* and ADR 38/..; *Trailer Brake Systems* - is recertified in accordance with the appropriate Sections of this National Code of Practice.

4. AFFECTING MODIFICATIONS

Modifications covered by this Section include any modification to the vehicle suspension that is likely to affect the vehicle's compliance with ADR's or the safe operation of the vehicle. Examples are given under each individual Modification Code.

5. GENERAL REQUIREMENTS

This Section applies to commercial vehicles and should be used in conjunction with other Sections of this National Code of Practice that are specific for the type of modification being performed. The following general requirements apply to all suspension modifications:

- Suspensions must be of an approved Load Sharing Suspension type (if applicable) as per DoTRS publications and instructions.
- All work performed must be in accordance with recognised engineering standards.
- It is recommended that only the manufacturer's optional suspensions (or equivalent) be used and that the installation be in accordance with the manufacturer's specifications. This includes the size of the frame rail, additional reinforcements, types of cross members and attachment arrangements.
- The type of suspension to be fitted should be suitable for the application of the vehicle.
- The mass ratings (maximum load and GCM) of the replacement suspension must be sufficient for the mass ratings of the modified vehicle. Refer to Section S of this National Code of Practice.
- If a load sharing type suspension is replaced with a non-load sharing type, the vehicle's registerable GVM must be reassessed in accordance with Section S of this National Code of Practice.
- Before any suspension substitution, ensure that the suspension to be fitted is compatible with the frame width and with the brake configuration and mounting.
- The new suspension must maintain the vehicle's overall balance (especially in pitching mode).

HEAVY VEHICLE MODIFICATIONS

- After any modification to the suspension, all associated components must be checked for clearance under full suspension travel.
- After any modification to the suspension, axle alignment should be checked and adjusted to the appropriate specification.
- Chassis strength should be reviewed in accordance with Section H of this National Code of Practice.

6. RECORDING

The Appendix to this document is Appendix F1 which:

- Summarises the scope of modification work that may be certified in accordance with Modification Code F1.
- Includes a check list of Sections of the National Code of Practice covering other areas of the vehicle which may have been affected by the modification and which should be analysed to determine whether they, too, require re-certification.
- Includes a checklist appropriate to Modification Code F1 that should be completed.

It is suggested that analysis work, sketches and other vehicle data, together with copies of any calculation sheet and the completed Checklists be retained by the Certifying Officer for at least the period specified in Part A of this National Code of Practice.

HEAVY VEHICLE MODIFICATIONS

Appendix F1

Modification Code F1

SUSPENSION SUBSTITUTION

Modifications that are covered under this Modification Code are:

1. Fitting of alternative suspension system.

Modifications that are **not** covered under this Modification Code are:

1. Re-rating of suspension systems.
2. Relocation of existing suspension systems.
3. Fitting of components not designed for automotive use.

NOTE: The modified vehicle/modifications must continue to comply with all applicable ADR's, Australian Standards or Regulations/Acts.

Outlined below are areas of the vehicle that may have been affected by the modifications and that may require recertification, testing and/or data to show compliance for the modified vehicle.

DETAIL**REQUIREMENTS**

Fitment of alternative suspension	National Code of Practice - Section F, Alternative manufacturer's specifications
Relocation of existing suspension	National Code of Practice - Section H
Rear axle installation	Modification Code D1
Front axle installation	Modification Code E1
Brake system modification	National Code of Practice - Section G
Chassis modification	National Code of Practice - Section H
Tailshaft alteration	Modification Code C1
Re-rating GVM	Modification Code S1
Re-rating GCM	Modification Code S3

HEAVY VEHICLE MODIFICATIONS

SUSPENSION SUBSTITUTION

SPECIFIC REQUIREMENTS

1. The replacement suspension must be assembled and fitted in accordance with the suspension manufacturer's instructions.
2. The replacement suspension assembly, including springs, bushes, pins and shock absorbers, must be in servicable recondition.
3. The replacement suspension must be the correct width to suit the vehicle chassis.
4. The axle(s) must be installed in the replacement suspension in accordance with the axle manufacturer's instructions, the suspension manufacturer's instructions and Sections D or E of this National Code of Practice with regard to any welding performed on the housing and the angle(s) of installation of the axle(s).
5. Spring hanger brackets, torque rod brackets and shock absorber brackets must be positioned and attached to the chassis in accordance with the suspension manufacturer's requirements and the vehicle manufacturer's requirements, where applicable (Refer to Section H - Chassis Frame of this National Code of Practice).
6. If bolts are used to attach suspension brackets to the web of the chassis, ISO Grade 10.9 (SAE Grade 8) bolts and self-locking nuts must be used. Fitted bolts are preferable but not essential. Bolts must be tightened to the correct torque.
7. Hardened washers should be fitted between the fastener and cast component unless spot faced.
8. Chassis cross members must be suitably selected and positioned for the type of suspension (Refer to Section H - Chassis Frame of this National Code of Practice).
9. All attachments including axle bump stops should be fastened to the web of the chassis.
10. It is recommended (and essential in some applications) that a rear suspension chassis liner be used (Refer to Section H - Chassis Frame of this National Code of Practice).
11. Variable ride height and constant ride height mechanisms, if fitted, must be fitted and adjusted in accordance with the suspension manufacturer's recommendations.

HEAVY VEHICLE MODIFICATIONS

Checklist F1

SUSPENSION SUBSTITUTION

(Y=Yes N=No)
delete if not applicable

- | | | | |
|-----|--|---|---|
| 1. | Is the replacement suspension suitable for the application of the vehicle? | Y | N |
| 2. | Are the maximum load rating and GCM rating of replacement suspension sufficient for the mass ratings of the modified vehicle? | Y | N |
| 3. | If a non-load sharing type of suspension is replacing a load sharing type of suspension, has the vehicle's GVM been reassessed in accordance with Section S of this National Code of Practice? | Y | N |
| 4. | Is the replacement suspension assembled and fitted in accordance with the suspension manufacturer's recommendations? | Y | N |
| 5. | Is the replacement suspension assembly, including springs and shock absorbers, in servicable condition? | Y | N |
| 6. | Is the replacement suspension the correct width to suit the chassis? | Y | N |
| 7. | Are the axle(s) installed in the replacement suspension in accordance with the axle manufacturer's instructions, the suspension manufacturer's instructions, and Section D or E of this National Code of Practice with regard to all welding on the axle housings and angle of installation? | Y | N |
| 8. | Are all suspension brackets (spring hanger brackets, torque rod brackets and shock absorber brackets) positioned and attached to the chassis in accordance with the suspension manufacturer's requirements and the vehicle manufacturer's requirements, where applicable? | Y | N |
| 9. | Are all suspension brackets attached to the web of the chassis by ISO 10.9 (SAE Grade 8) bolts with self-locking nuts? | Y | N |
| 10. | Are all bolts tightened to the correct torque? | Y | N |
| 11. | Are all chassis cross members selected and positioned in accordance with the vehicle manufacturer's recommendations or Section H - Chassis Frame of this National Code of Practice? | Y | N |
| 12. | Is there clearance for all components under full suspension travel? | Y | N |
| 13. | Is the variable ride height or constant ride height mechanism, if fitted, fitted and adjusted in accordance with the suspension manufacturer's recommendations? | Y | N |
| 14. | Is the quality of workmanship to a satisfactory standard? | Y | N |

NOTE: If the answer to any relevant question is "NO", the modification is not acceptable.

HEAVY VEHICLE MODIFICATIONS

Vehicle Chassis No/VIN:

Vehicle Modifier:

Examined by:

Company (if applicable):.....

Certifying Officer No:.....Modification Certificate No:.....

Modification Plate No:.....

Signed:..... Date:.....

HEAVY VEHICLE MODIFICATIONS
TRAILER SUSPENSION MODIFICATIONS

1. SCOPE

This section relates to the installation of suspension systems to heavy trailers. It provides guidelines for the trailer modifier and specifies minimum requirements the trailer modifier should ensure are met when installing suspensions.

This Code is applicable in modifications where a different suspension is substituted for the original.

This Code is **not** applicable to the relocation of an existing suspension on a trailer chassis. The modifier is referred to Code H5 for this modification.

This modification scheme does **not** apply to a trailer that, after modification, requires a change of the registration category of the trailer, for example, semi-trailer to dog trailer, pig trailer to dog trailer, semi-trailer to a dolly, etc. Such trailers are regarded as newly manufactured and must be issued with a new Vehicle Identification Number (VIN) and fitted with a new Compliance Plate issued by the DoTRS.

NOTE: This Section must be read in conjunction with other relevant Sections of this National Code of Practice to ensure the trailer is modified in a satisfactory manner. The Certifying Officer should ensure that the modified trailer meets the requirements of the relevant jurisdiction and the ADR's.

Certification of the trailer to Code G3 or G8 of this National Code of Practice is required with any change in trailer suspension.

2. GENERAL INFORMATION

To simplify the analysis of the modifications, it is recommended that the modified trailer should, where possible, remain within the options offered by the first manufacturer.

Because of the various trailer manufacturers' and suspension manufacturers' design philosophies and methods of manufacture, the manner of installation will differ somewhat between trailers and suspensions of different makes or types. However, the modifier must always ensure that good engineering practice is followed. It is recommended that the particular trailer, suspension, and axle manufacturers' recommendations are followed whenever available.

3. ADRs AFFECTED

ADR 38/.. is affected by suspension modifications. If the suspension service and emergency braking skid limits of the replacement suspension differ from those of the original suspension, the ADR 38/.. calculations must be conducted to determine whether ADR 38/.. compliance is maintained.

In addition, the modifier must ensure the trailer mass rating and other traffic regulations pertaining to the trailer can be met.

This should be done **before** any modifications are commenced.

4. AFFECTING MODIFICATIONS

Modifications covered by this Code are the substitution of the suspension system with another suspension system on heavy trailers.

HEAVY VEHICLE MODIFICATIONS**5. GENERAL REQUIREMENTS**

It is recommended that the specifications of the modified trailer remain within the options offered by the original manufacturer. In this manner, the design process, sourcing of components, and evaluation of the modification is simplified.

If the proposed modifications render the trailer identical to a specification offered by the original manufacturer, including suspension and axle configuration, chassis design, braking system, and kingpin to centre line of suspension dimension, then provided all work is appropriately executed, no additional evaluation of the modifications would be required.

The modified trailer must satisfy the minimum criteria given below:

- The proposed suspension system must be of an approved Load Sharing Suspension type (if applicable), as per the DoTRS publications and instructions. The proposed suspension must be one designed for heavy trailer application.
- Recertification of the braking system under the G3 or G8 Code is required for any change in suspension.
- The suspension and axle combination must be suitable for the proposed mass rating for the modified trailer. Re-rating of the ATM is covered under the S7 Code of this National Code of Practice. Re-rating is always required if the axle configuration is changed.
- Chassis strength should be reviewed and confirmed to be adequate in accordance with the H5 Code of this National Code of Practice.
- The attachment of suspension hangers to the trailer frame must be adequate for all operating conditions. Attachment must be able to accommodate high shock loads from poor road surfaces, and loads from braking forces (forward and reverse).
- The proposed suspension must be suitable for the chassis width of the trailer.
- The slope of the trailer to suit the turntable height and application must be considered when installing the suspension and the axles installed with the appropriate spacers.
- The configuration and mounting of the brake components, especially brake chambers and chamber mounting brackets, must be suitable for the suspension.
- All trailer components must have sufficient clearance with the suspension moving through its full range of travel.
- Shock absorbers should not fully extend or fully compress in the normal operation of the suspension.
- The attachment points for axle catch straps or shock absorber mounts must be adequate to support the mass to the axle plus any residual spring force.

5.1 Chassis Components

Refer to Code H5 of this National Code of Practice.

The chassis must be adequate to support the load transmitted by the suspension. The trailer manufacturer's recommendations and suspension manufacturer's recommendations should be followed wherever possible.

HEAVY VEHICLE MODIFICATIONS

Cross members should be welded or bolted to the side rail webs only. Welding or bolting through the rail flanges is **not** permitted. RSJ cross members must be welded by the web only. Reinforcement of the cross member to side rail connection is generally required. An example of a suitable arrangement is shown below.

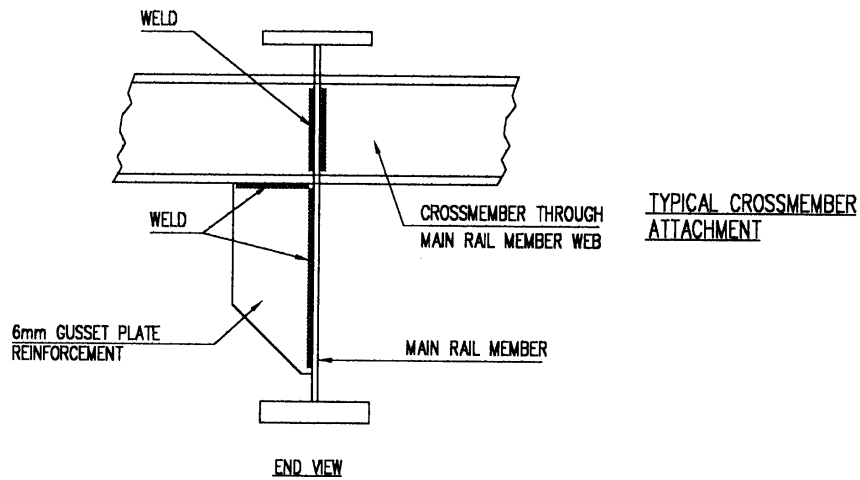

The ends of any reinforcing section should be tapered to reduce the abrupt change in chassis stiffness as a result of the installation of the reinforcement. The thickness of any reinforcement section should not exceed the thickness of the chassis rail material at the point of reinforcement.

The design of cross members must be suitable for the type of suspension to be fitted and the design of the frame rails and cross members must allow the load from the suspension spring hangers to be evenly distributed into the chassis.

The frame rail web should be suitably reinforced at the connection of the suspension hanger bracket, such as in the method shown below.

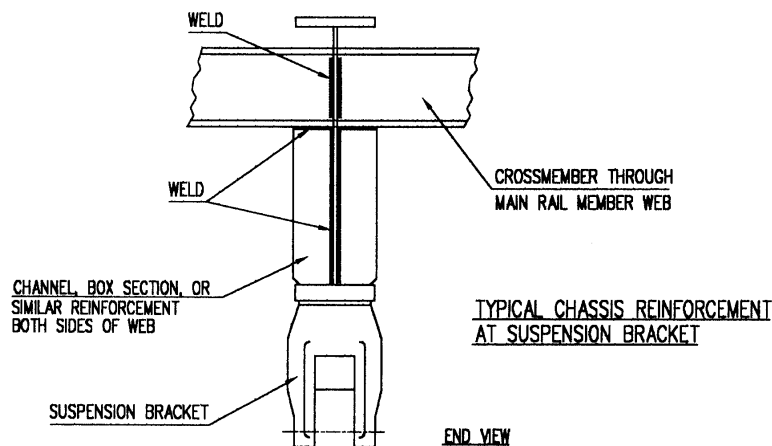

The frame will require adequate cross bracing at the suspension mounting positions. The material used for the cross bracing is often dictated by the design of the suspension brackets. Cross bracing at least equivalent to the original manufacturer's must be incorporated into the chassis at the suspension mounting positions.

HEAVY VEHICLE MODIFICATIONS

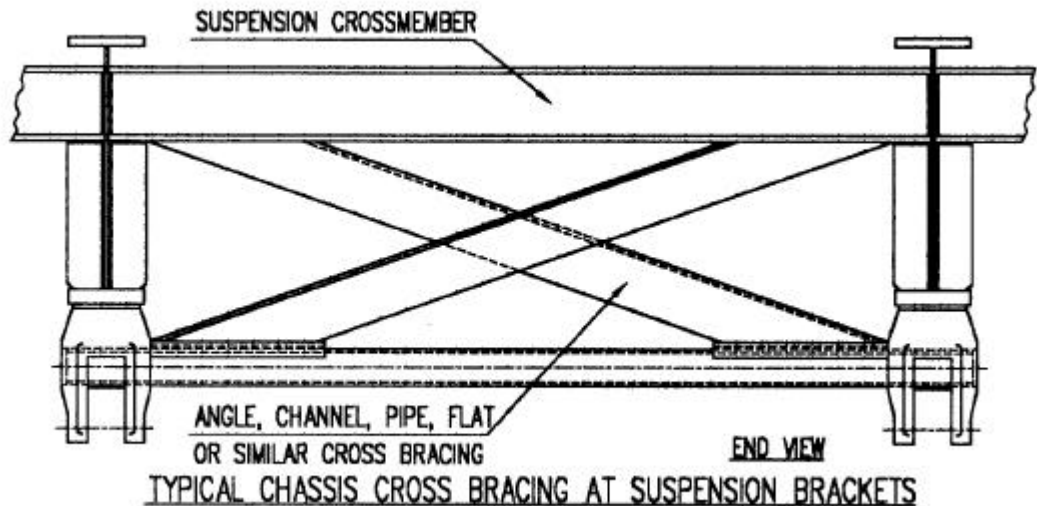

Holes are to be drilled or punched. Flame cut holes are not permitted, unless ground or reinforced.

Fastener hole diameters must not exceed the fastener diameter by more than 1.5mm and should not be elongated.

All bolts for structural purposes must at least be ISO Metric Grade 8.8 or SAE Grade 5.

All structural bolts should be fitted with hardened washers and self-locking nuts. Spring type lock washers are not permitted on structural members.

All bolts must be tightened in an acceptable manner to the correct torque.

Alteration to air or hydraulic lines should use piping of the same bore as the original manufacturer's, and must not introduce additional restrictions at fittings.

5.2 Welding on Frame Rails

Before any welding is performed on the trailer chassis, the material specification of the frame rail must be determined to ensure the correct welding procedure is used. All welding must be carried out in accordance with the original trailer manufacturer's and suspension manufacturer's recommendations, and AS 1554 SAA Structural Steel Welding Code or similar accepted standard and carried out by a competent tradesperson.

Always attach the earth welding cable terminal as close as possible to the region in which welding is being carried out. Never attach the welding earth cable terminal to components such as axles, springs or other suspension components. Arcing on these components may cause serious damage to bearing surfaces, springs, or other stressed components. Special attention must be paid to suspension parabolic leaf springs and air suspension springs. Every care must be taken to protect these components against welding sparks and spatter.

Hoses and conduits, for example for brake and electrical systems, should be protected from cutting and welding sparks and spatter. Plastic and rubber materials should not be exposed to temperatures above 80°C.

Auxiliary air, oil, and fuel tanks in the vicinity of welding should be removed.

As a precaution, electronic components for the anti-lock braking system, if fitted, should be disconnected before the commencement of welding.

HEAVY VEHICLE MODIFICATIONS

Except in the case of joining the rail flange or where fitting longitudinal strapping, welds should not be placed within 25mm of the flanges.

Finished welds must not exhibit excessive undercut.

Welds transverse to the rail flanges should be avoided wherever possible, and are **not** permitted in regions of high stress.

Special attention should be made to joint preparation, pre- and post-heat, and welding consumables. Low hydrogen consumables should be used for welding of suspension brackets.

All paint, dirt, and grease should be removed from the region of the weld prior to welding. In low ambient temperatures or if there is dew or other moisture present, the region to be welded should be warmed slightly with an oxy-fuel torch.

Welds must not be cooled with water.

The minimum length of any weld should be 30mm.

6. RECORDING

The Appendix to this document is Appendix F2 which:

- Outlines specific requirements pertaining to trailer suspension modifications with should be addressed by the modifier.
- Includes a checklist appropriate to Modification Code F2 that must be completed. Analysis work, sketches and other trailer data, any calculation sheets, and the completed checklist should be retained by the Certifying Officer for at least the period specified in Part A of this National Code of Practice.

HEAVY VEHICLE MODIFICATIONS**Appendix F2****Modification Code F2****TRAILER SUSPENSION MODIFICATIONS**

Modifications that are covered under this Modification Code are:

1. Trailer suspension modifications where the registration category of configuration of the trailer to be modified is not changed.

Modifications that are **not** covered under this Modification Code are:

1. Modifications that change the registration category of the trailer.
2. Changes in the mass rating of trailers.
3. The relocating of suspension systems (refer to Code H5).

NOTE: The modified vehicle/modifications must continue to comply with all applicable ADR's, Australian Standards or Regulations/Acts.

Outlined below are areas of the trailer that may have been affected by the modifications and that may require recertification, testing, and/or data to show compliance for the modified trailer.

DETAIL**REQUIREMENTS**

ATM re-rating

Modification Code S7

Trailer chassis modifications

Modification Code H5

Trailer Brake System Upgrading - Non standard

Modification Code G3

Trailer Brake System Upgrading - Standard

Modification Code G8

HEAVY VEHICLE MODIFICATIONS
TRAILER SUSPENSION MODIFICATIONS
SPECIFIC REQUIREMENTS

1.0 Suspension Installation

The manufacturer's instructions for installation should be followed when available. In the event of these being unavailable, the following guidelines should be followed.

2.0 Hanger Bracket Installation

The forward suspension hanger brackets should be located on the chassis approximately at the required position in accordance with the required kingpin to suspension centre line dimension and axle spacing.

The two forward hangers should be aligned precisely square with the frame and in line longitudinally and transversely, by measuring to the kingpin or other front towing connection. The hanger position should be accurate within plus or minus 2mm.

These hangers should be tacked in position.

The next rearward hangers should be positioned by measuring back from the forward hangers, and tacked in position, square to the frame.

The above procedure should be used to locate all subsequent hanger brackets.

The hanger brackets should be welded to the chassis in accordance with the manufacturers' recommendations. Low hydrogen consumables should be used. Welds transverse to the rail flange should be avoided where possible.

3.0 Axle and Spring Assembly

The spring seats should be positioned on the axle at the correct spacing and rotation, so that the spring mating faces are parallel with each other. The centre of the centre-bolt hole should be at the top centre of the axle housing.

The spring seats should be tacked in position.

Clearances between the spring and axle equipment such as brake chambers or brake chamber brackets should be checked with the springs in position on the axles.

The springs should be removed and the spring seats welded to the axle in accordance with the axle manufacturer's instructions. Low hydrogen consumables should be used.

The springs should be positioned on the axle seats, ensuring that any spacers required to accommodate the slope and camber of the trailer chassis are included. The springs should be aligned square to the axle and fastened, ensuring that all fasteners are correctly tightened.

4.0 Suspension Assembly

The suspension should be assembled in the hanger brackets in accordance with the manufacturer's instructions, ensuring that all fasteners are correctly tightened.

5.0 Axle Installation

The axle and spring assembly should be fitted into the hanger brackets.

Prior to alignment of the axles, the suspension should be free and loose in its rest position.

HEAVY VEHICLE MODIFICATIONS

The alignment of the forward axle should be checked using specialist optical alignment equipment or by the following manner:

1. Accurately measure the distance from the king pin to the centre line of the axle spindles on both sides. (It is recommended that spindle extensions are used).
2. Align the forward axle square to the king pin or front towing attachment, by changing the length of adjustable radius rods, shimming the ends of fixed radius rods, or similar as dictated by the design of the suspension.
3. Tighten the adjustment fasteners on the forward axle to the correct torque.
4. Align the next axle to the forward axle by measuring from the centre lines of the axle spindles on both sides and adjusting as above. Align any subsequent axles in the same manner.

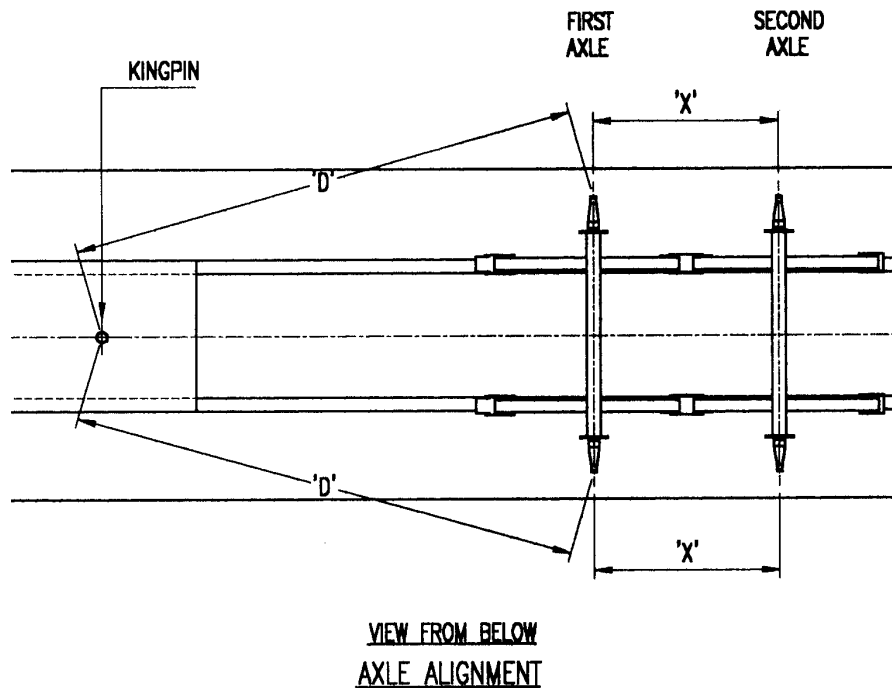
**6.0 Inspection**

After the installation and alignment, the unit should be visually checked, paying attention to the following items:

1. All springs should be properly located on the wear pads.
2. Equalisers of centre rocker type suspensions should be parallel to a line through the axle centres.
3. There should be sufficient and even clearance between the springs and the hanger brackets on both sides.
4. There should be sufficient clearance between the suspension/axle assembly and the remainder of the trailer under all loading and operational conditions. Special attention should be paid to air bag type suspensions, to ensure that there is sufficient clearance (especially at the tyres) in the event of a loss of air pressure in the bags.
5. All fasteners are to be tightened to the correct torque.

HEAVY VEHICLE MODIFICATIONS

7.0 Fitting or the removal of axles

It is likely that any change in the number of axles will result in a change in the mass rating of the trailer. Refer to Code S7 of this National Code of Practice.

8.0 Change in trailer mass rating

If the suspension modification alters the trailer's mass rating, the trailer frame and braking system must be demonstrated to be able accommodate this change by satisfying the requirements given in Section G, H, and S of this National Code of Practice.

Any mass re-rating of a trailer must be performed in accordance with the requirements specified in Code S7 of this National Code of Practice.

HEAVY VEHICLE MODIFICATIONS

Checklist F2

TRAILER SUSPENSION MODIFICATIONS

(Y=Yes N=No)
Delete if not applicable

- | | | | |
|-----|--|---|---|
| 1. | Is the modified chassis configuration the same as the original configuration? (i.e. is the category of registration unchanged)? | Y | N |
| 2. | Is the slope suitable for the intended application of the trailer? | Y | N |
| 2. | Is the replacement suspension an approved load-sharing type as per the DoTRS publications and instructions? | Y | N |
| 4. | Has the trailer braking system been re-certified under the G3 or G8 Codes of this National Code of Practice? | Y | N |
| 5. | Is the replacement suspension system suitable for the proposed mass rating of the trailer? | Y | N |
| 6. | If mass re-rating is required, has it been performed in accordance with Code S7 of this National Code of Practice? | Y | N |
| 7. | Is the replacement suspension system of the correct width for the chassis? | Y | N |
| 8. | Are all suspension brackets suitably and adequately attached to the chassis? | Y | N |
| 8. | Has the chassis been suitably reinforced at the attachment positions of the suspension hanger brackets and associated components? | Y | N |
| 10. | Is the chassis cross bracing suitable for the type of suspension? | Y | N |
| 11. | Do all suspension, axle, wheel, and chassis components have sufficient clearance to accommodate the entire range of travel of the suspension, including the complete deflation of an air bag in an air suspension? | Y | N |
| 12. | Are axle catch straps and shock absorber mounts adequately designed, constructed and attached? | Y | N |
| 13. | Have good welding practices been followed? | Y | N |
| 14. | Do all related chassis modifications to the trailer meet the requirements of Code H5 of this National Code of Practice? | Y | N |
| 15. | Have the suspension brackets been properly positioned on the chassis? | Y | N |
| 16. | Has the suspension been installed in accordance with the suspension manufacturer's instructions? | Y | N |
| 17. | Does the installation allow the proper alignment of the axles and have the axles been aligned? | Y | N |
| 18. | Have the general requirements of Section 5 of this National Code of Practice been met? | Y | N |
| 19. | Is the quality of workmanship to a satisfactory standard? | Y | N |

NOTE: If the answer to any relevant question is "NO", the modification is not acceptable.

HEAVY VEHICLE MODIFICATIONS

Vehicle Chassis No/VIN:

Vehicle Modifier:

Examined by:

Company (if applicable):.....

Certifying Officer No:.....Modification Certificate No:.....

Modification Plate No:.....

Signed:..... Date:.....